

REFRIGERATED COUNTER 2 DOORS WITH COCKTAIL BAR STATION

€4,485.00

SKU:

7489.6000

Discover the convenience of our refrigerated counter with cocktail bar station!



The refrigerated cocktail bar station with 2 doors is ideal for professional bartenders and provides everything you need to prepare the perfect cocktails. The front features a handy 'speedrail' for quick access to bottles, and a shelf offers space for a blender. Additionally, the station comes with a faucet, sink, glass washer, cutting board, and an electrical outlet for connecting the blender. The ventilated cooling system ensures efficient cooling, while automatic defrost minimizes maintenance. The dimensions are 1200x760x1000 mm (LxDxH) - consumption 0.26 kW - capacity 180 liters - temp. +2/+8°C - weight 95 kg.

Key Features:

- **Ice bin with dividers:** provides space for various products like ice and fruit.
- **Speedrail at the front:** for quick access to bottles.
- **Sink with glass washer:** for a hygienic workspace and quick glass cleaning.
- **200x200mm cutting board:** perfect for cutting garnishes or fruit.
- **Shelf for blender (290x240mm) with electrical outlet:** for connecting your blender.

The refrigerated cocktail bar station is the perfect solution for any bar or event seeking efficiency, functionality, and style. Order your refrigerated counter with cocktail bar station today and give your bar workspace the upgrade it deserves!





EAN code	6153304154154	Width (mm)	1200
Depth (mm)	760	Height (mm)	1000
Material	Stainless steel	Gross Weight (kg)	112
Net weight(kg)	95	Voltage (Volt)	230
Frequency (Hz)	50	Electrical power (kW)	0.26
Cooling agent	R 290	Temperature range (°C)	-2/+8
Gross Capacity (Ltr)	180	Operation	Digital
Temperature display	Yes, digital	Type of cooling	Ventilated
Lockable	Yes	Mobile	No
Number of doors	2	Door left / right hinging	Left and right hinged
Noise level (dB)	65	Defrost	Automatic
Max. ambient temperature (°C)	43	Insulation thickness (mm)	50
Power consumption (Kw/24h)	4.08	Brand	COMBISTEEL
Refrigerant quantity (gr)	80	Energy Class (A/G)	No energy label required
Plug and play (EU only)	Yes	Parcel ready	No

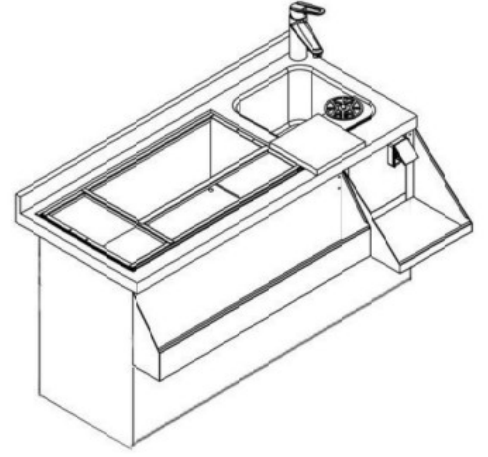
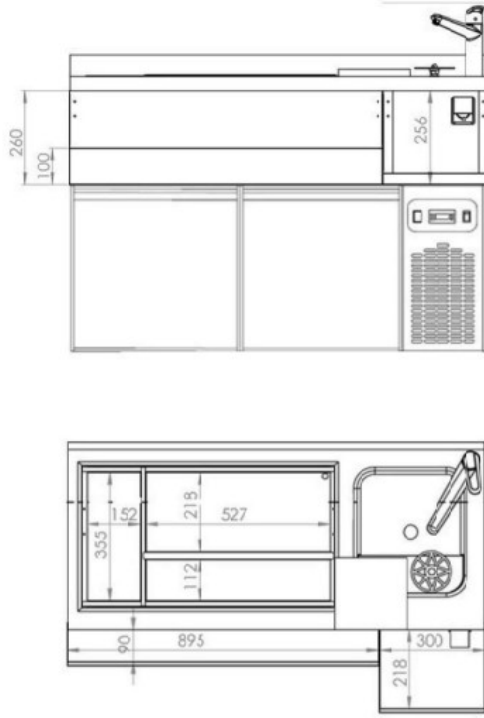

DIŞ BOYUTLAR / OUTSIDE DIMENSIONS = 1300X700X1000
İÇ BOYUTLAR / IN SIDE DIMENSIONS = 830X562X390